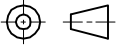

SOURCE DRAWING - FOR REFERENCE ONLY

NOTES:
1. "*" INDICATES CABLE LENGTH IN METERS. CONTACT TURCK TO ORDER SPECIFIC LENGTHS.

RELATED DOCUMENTS 1. 2. 3. 4.	3RD ANGLE PROJECTION 	THIS DRAWING IS CONFIDENTIAL AND THE PROPERTY OF TURCK INC. USE OF THIS DOCUMENT WITHOUT WRITTEN PERMISSION IS PROHIBITED.	3000 CAMPUS DRIVE MINNEAPOLIS, MN 55441 1-800-544-7769 (763) 553-7300 (763) 553-0708 fax www.turck.us
MATERIAL SEE SPECIFICATIONS	ALL DIMENSIONS DISPLAYED ON THIS DRAWING ARE FOR REFERENCE ONLY	DRFT RDS APVD T.S.	DATE 03/04/14 SCALE 1=1.3
FINISH SEE SPECIFICATIONS	CONTACT TURCK FOR MORE INFORMATION	DESCRIPTION WSM 40-WKM 50-*M/BL67	
DO NOT SCALE THIS DRAWING		UNIT OF MEASUREMENT MILLIMETER [INCH]	IDENTIFICATION NO. REV B
B UPDATE PROTECTION CLASS	CBM 04/13/21 76628	FILE: 777033022	
REV DESCRIPTION	BY DATE ECO NO.	SHEET 1 OF 1	